

Scanning	LIB.

SPECIFICATION FOR APPROVAL

• CUSTOMER	:	
• ITEM	:	Power Supply Unit.
• DESCRIPTION	:	LCD & LED Monitor Power Supply
• CUSTOMER P/NO	:	
• SUPPLIER P/NO	:	GP-4500
• DATE	:	2021-12-20

CUSTOMER	EN'GR	CHKD	APPD

SUPPLIER	EN'GR	CHKD	APPD
GAON POWERTEK CO., LTD.			

MAKER : GAON POWERTEK Co., Ltd.



TEL : 82-2-6091-5005

FAX : 82-2-6091-5006

DOCUMENTATION FOR APPROVAL

Product	LCD & LED Monitor Power Supply
Model Name	GP - 4500
Customer P/No.	

CONTENTS

NO.	A table of contents	Page
1	Documentation of approval	2
2	Contents	3
3	Revision History	4
4	<u>Specification</u> 1. INTRODUCTION 1.1 Product Description 1.2 Parameter Specification 2. ELECTRICAL REQUIREMENTS 2.1 Input Requirements 2.2 Output Requirements 2.3 Power Output Protection 3. RELIABILITY 3.1 Mean Time Between Failure(MTBF) 3.2 Life/Power On Hours 3.3 Burn-in Test Condition 3.4. Derating characteristic data 4. SAFETY & EMS 4.1 Earth Leakage current 4.2 Hi-Pot Test(Dielectric withstand voltage) 4.3 Insulation Resistance 4.4 Input AC Surge 4.5 Surge & Impulse Test 4.6 RFI / EMI Standards 4.7 Safety Standards 5. ENVIRONMENT REQUIREMENTS 5.1 Temperature 5.2 Humidity 6. POWER ON/OFF SIGNAL 6.1 LOW SIGNAL 6.2 HIGH SIGNAL 6.3 AUTO SIGNAL 6.4 Power on/off signal select 7. GENERAL SAFETY INSTRUCTIONS 8. CONNECTOR PIN ASSIGNMENT & SPECIFICATION 9. P.C.B ASSEMBLY DIMENSION	5
5	BLOCK DIAGRAM	15
6	BAR-CODE LABEL DESCRIPTION	17

Revision history

Documentation of Approval Revision history

Rev No.	Contents	Date of approval	Checked	Remark
AA	Enactment	2021/12/20		

SPECIFICATION

1. INTRODUCTION

1.1 Product Description

This specification defines the input, output, performance characteristics, environment, noise and safety requirements for a LCD & LED Monitor (TV) power supply.

1.2 Parameter Specification

Unless specification otherwise, all parameters must be met over the limit of temperature Load, and input voltage.

2. ELECTRICAL REQUIREMENTS

2.1 Input Requirements

2.1.1 Input Voltages

- Normal Voltage: 100 ~ 240 Vrms
- Voltage Range : 85 ~ 264 Vrms

2.1.2 Input Frequency

- Normal Frequency: 50 ~ 60Hz
- Frequency range : 47 ~ 63Hz

2.1.3 Input Current

- under 6 Arms at 100Vac & Maximum Load

2.1.4 Power Factor

- PF \geq 0.9 at Maximum Load & 100Vac~240Vac condition.

2.1.5 Configuration

- 3 Conductors (Live, Neutral, F.G)

2.1.6 Input Fuse

- The live line side of the input shall have a fuse.

2.1.7 Primary Over Current Protection

- An adequate internal fuse on the AC input line shall be provided.

2.1.8 Inrush Current

The inrush current of power supply shall be less than the rating of its critical components (including bulk rectifiers and surge limiting device) for all condition of line voltage of 2.1.1

- Cold start: under 60Ap-p at AC 100Vac ~ 240Vac

2.1.9 Efficiency

The power supply efficiency shall be more than 85% measure at the 220Vac maximum load as specified in paragraph 2.2.1 with the AC input set at the nominal voltage.

2.2 Output Requirements

2.2.1 Maximum Output Voltage and Current

Output Name	Output Typical [V]	OUTPUT REGULATION LIMIT	Output Current(A)			Remark
			Min.	Typ.	Max. *1)	
+5VS	+5	4.75VDC ~ 5.25VDC	0	1.0	1.2	
+5VD	+5	4.75VDC ~ 5.25VDC	0.1	2.5	3.0	
+12V	+12	11.4VDC ~ 12.6VDC	0.2	7.0	8.0	Total Maximum Power 432W
+24V	+24	22.8VDC ~25.2VDC	1.0	15.0	16.5	

*1) This power supply is a 60-minute period, the maximum current that can be used for about 10-minutes with a maximum current.

2.2.2 Ripple and Noise

Ripple and noise are defined as periodic or random signal over frequency band of 10Hz to 20MHz. Measurements shall be made with an oscilloscope with 20MHz bandwidth.

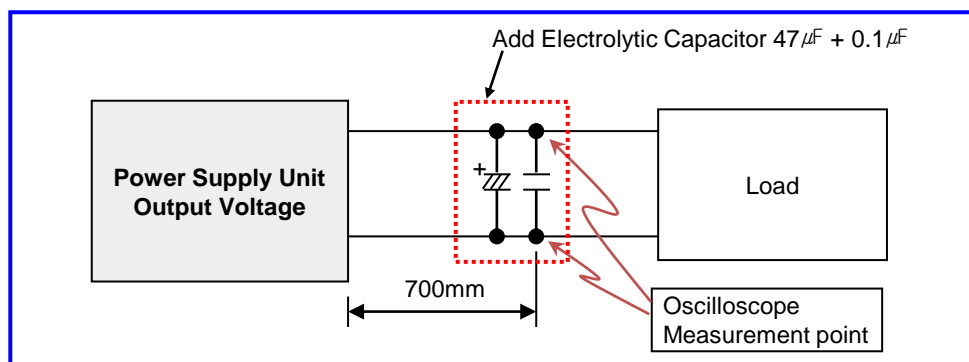

Output Voltage	5VS	5VD	12V	24V
Ripple Voltage Range (mVp-p)	150mV	150mv	240mV	480mV

※ Ripple & noise are measured at 20MHz of bandwidth by using a 12" twisted pair-wire terminated with a 0.1uF & 47uF parallel capacitor.

☞ Test condition

- Temperature: 25°C room temperature
- Test equipment: Resistance load

2.2.3 Overshoot

The output overshoot at turn –on shall not exceed 20% of normal voltage value with or without the load connected.

2.2.4 Hold up Time

The power supply shall maintain voltage regulation within the specified limits in paragraph 2.2.1 for at least 10ms after lost of input voltage measure at 220Vac and at maximum output load.

2.2.5 Output Rise Time

At turn on the rise time of output voltage shall be less than 2000msec.

※ Measured from the 10% point to the 90% point of the normal

☞ Test condition

- Temperature: 25°C room temperature
- Test equipment: Resistance load

2.2.6 Power Saving Management [PS - ON = OFF Mode]

Output Voltage	5VS	5VD	12V	24V
Load [A]	30mA	-		
Wattage [W]	≤ 0.5W [at 230Vac / 50Hz]			

2.3 Power Output Protection

2.3.1 Over Current Protection(OCP)

The power supply shall not be damaged by a over current from the output to return Line. Protection to be invoked if current exceed maximum rating about 10% or more. The other lines shell be in maximum load condition

2.3.2 Over Voltage Protection(OVP)

The voltage will not exceed the upper trip limit. Noise spikes that exceed the lower trip limit for less than 10μs will not clamp the output voltage to zero.

2.3.3 Short Circuit Protection(SCP)

An output short circuit is defined as output impedance of less than 0.1 ohms.
The power supply shall not be damaged by short between DC output and DC ground.

2.3.4 Specification of Protection operating

NO	Output Voltage Name	*1) Over Current Protection		Over Voltage Protection		Short circuit Protection
		Range[A]	Protection	Range[V]	Protection	
1	5VS	1.5A more	Auto Recovery Or Shut Down	5.6 ~ 8	Auto Recovery	Auto Recovery Or Shut Down
2	5VD	3.0A more	Auto Recovery Or Shut Down	5.6 ~ 8	Auto Recovery	Auto Recovery Or Shut Down
3	12V	7.5A more	Auto Recovery Or Shut Down	15 ~ 20	Auto Recovery	Auto Recovery Or Shut Down
4	24V	17A more	Auto Recovery Or Shut Down	30 ~ 37	Auto Recovery	Auto Recovery Or Shut Down

*1 The O.C.P point is measured when other output load is a maximum.
No hardware failure and No fire, when the output voltage decrease to 10%(Voltage Drop)

3. RELIABILITY

3.1 Mean Time Between Failure(MTBF)

The power supply shall be designed and produced to have a mean time between failures (MTBF) Of 40,000 operating hours at 90% confidence – level while operating under the following condition.

- AC input voltage : 230Vac
- Duty cycle : 6hours ON, 2hours OFF
- Ambient Temp. : 25 ± 2°C
- Humidity : prevailing condition

3.2 Life/Power On Hours

The power supply must be designed to operate for 40,000 power on hours.
About 5 years at an ambient temperature of 25°C

3.3 Burn-in Test Condition

More than 1 hours at 40°C(±5°C), Normal input voltage.
AC on/off must be test 1 time after burn-in.

Output Voltage	5VS	5VD	12V	24V
Aging Load [A]	1	2.4	3	11

- ☞ Test condition
- Test equipment: Electronic load

3.4. Derating characteristic data

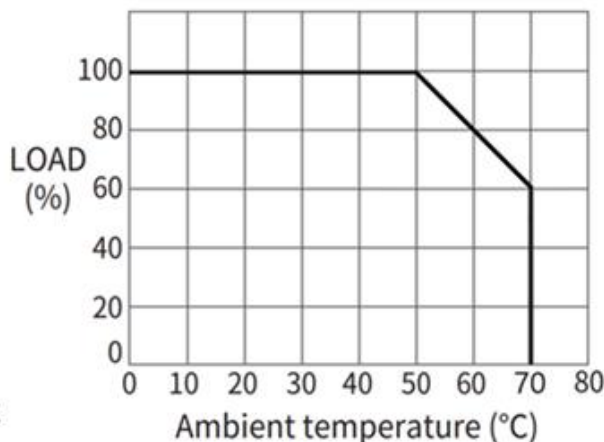
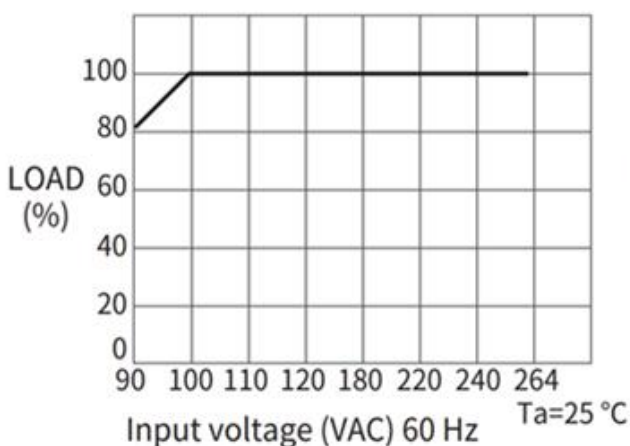

4. SAFETY & EMS



4.1 Earth Leakage current

The power supply leakage current shall be less than 0.5mA

4.2 Hi-Pot Test (Dielectric withstand voltage)

- ① Primary to Secondary : 3.0KVac for 1 minute
→ 3.6KVac for 1 seconds (mass production)
 - ② Primary to F.G : 1.5KVac for 1 minute
→ 1.8KVac for 1 seconds (mass production)
- ※ Cut-off current : 10mA

4.3 Insulation Resistance

Insulation resistance shall be 8MΩ or more at 500Vdc between primary Live, Neutral line and secondary.

4.4 Input AC Surge

The power supply withstand 300Vrms input for 10 seconds.

4.5 Surge & Impulse Test

- ① Lightning Surge : ±4kV(L1 ~ L2) 6 time, ±4kV(L1 ~ FG, L2 ~ FG) 6 times
- ② Impulse Noise Test : 2kV, Normal/Common mode, Polarity(+,-) / Phase(0° ~ 360°)

4.6 RFI / EMI Standards

The power supply shall comply with a following RFI/EMI standards when tested in a system configuration.

- CISPR, class B

The limits shall be met with a margin of at least more than 5dB at all applicable frequencies.

4.7 Safety Standards

The Power Supply Unit shall be tested with the following safety standards.

- UL60950, UL6500
- IEC60950, IEC60065
- EN60950, EN60065

5. ENVIRONMENT REQUIREMENTS

5.1 Temperature

- Operating Temp. : 0 ~ 50°C (Without Case)
- Storage Temp. : -10 ~ 65°C (Without Case)

5.2 Humidity

- Operation humidity : 30 ~ 85% non-condensing
- Storage humidity : 5 ~ 90% non-condensing

6. POWER ON/OFF SIGNAL

6.1 LOW Signal

- Power On Level : 0V ~ 0.5V
- Power Off Level : 2.5V ~ 5V

6.2 HIGH Signal

- Power On Level : 2.5V ~ 5V
- Power Off Level : 0V ~ 0.5V

6.3 AUTO Signal

- Power On Level : Pin open (Always On Mode)
- Power Off Level : Mode does not exist

6.4 ACD (AC Detect) Output Signal

- High logic more than 2.5V
- Low logic less than 0.7V

6.5 Power on/off signal select

- Depends on the switch on the PCB components L/N. SW 550

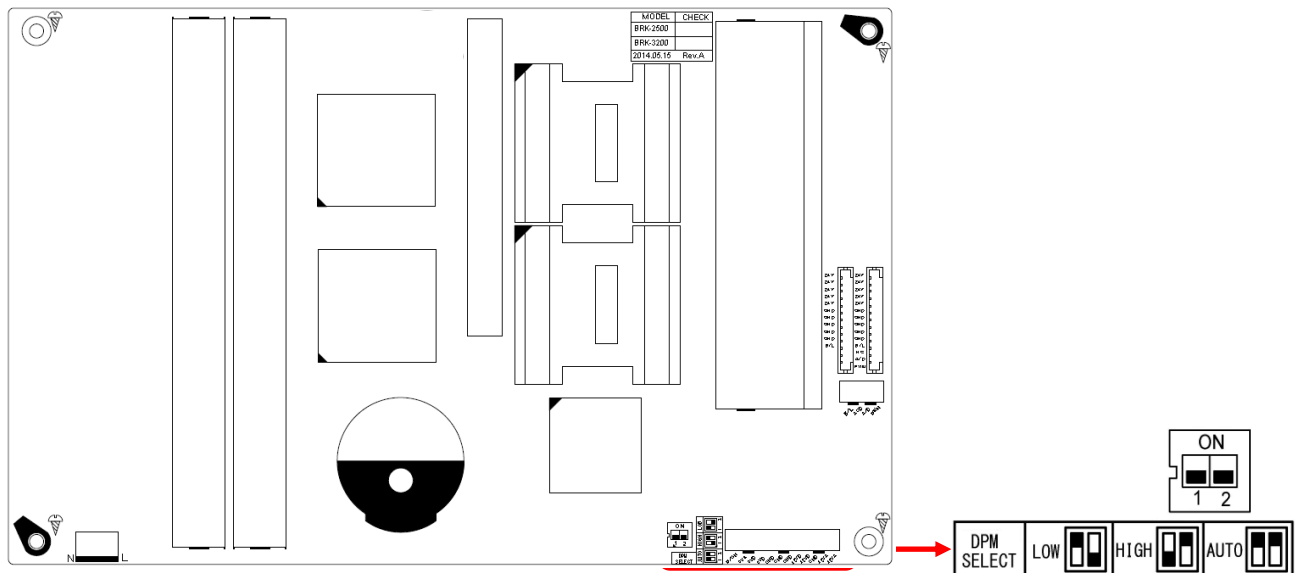

7. GENERAL SAFETY & ASSEMBLY INSTRUCTIONS

- This power supply is designed for usage within described equipment or enclosures.
For safe installation and operation of this product, carefully follow the instructions below:

- (1) Do not install, test or operate this product near water, and do not spill any liquid on it.
- (2) Do not operate this product unless it is in a secure position.
- (3) This product should be installed in a restricted access location accessible to authorized competent personnel only.
- (4) This product must be reliably earthed and professionally installed in accordance with the prevailing electrical wiring regulations and safety standards.
- (5) The output power taken from the power supply must not exceed the rating stated on the power supply label.
- (6) All servicing, repair and testing of this product must be carried out by competent personnel who are fully conversant with the hazards of AC line operated equipment and with the particular dangers associated with switch mode power supplies.
- (7) Dangerous voltages are present within the power supply. Power must be disconnected before servicing.
- (8) After disconnecting the AC source, allow 5 minutes before touching the unit to allow capacitors within the unit to discharge.
- (9) All four 4 mm diameter mounting holes at the corners of the unit must be used to secure the power supply.
To conform to EMI specifications, solder pads located around the mounting holes on the underside of the pcb must make electrical connection with the chassis.
Washers and other mounting hardware must not exceed 8mm in diameter.
- (10) A minimum of 6.5mm creepage and 4.5mm clearance must be maintained between the power supply and the equipment chassis. If the mounting spacer height is less than 8mm, basic insulation must be provided between the power supply and the equipment chassis.
- (11) Heat-sinks within this power supply are live and must not be touched when the unit is in operation.
- (12) For convection cooling, ensure that adequate ventilation is provided to allow air to circulate naturally.
- (13) In order for proper convection cooling, the heat-sink must be installed proper in alignment according to the standard mentioned below.
 - The assembly direction of the SMPS should be the direction of gravity and the wing of the heat-sink horizontal.
 - Air flow direction should be parallel to fins is recommended.
 - Because in this case, air moves along the longer distance through fins.
 - Whereas when air flows in the direction perpendicular to fins. Air does not reach inside area of the heat sink.

- [Recommendation] Appropriate assembly direction for SMPS heat dissipation and convection flow.

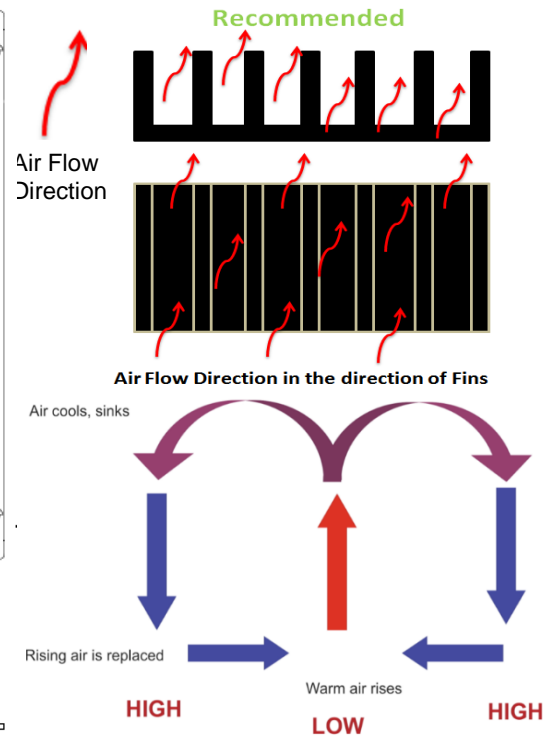
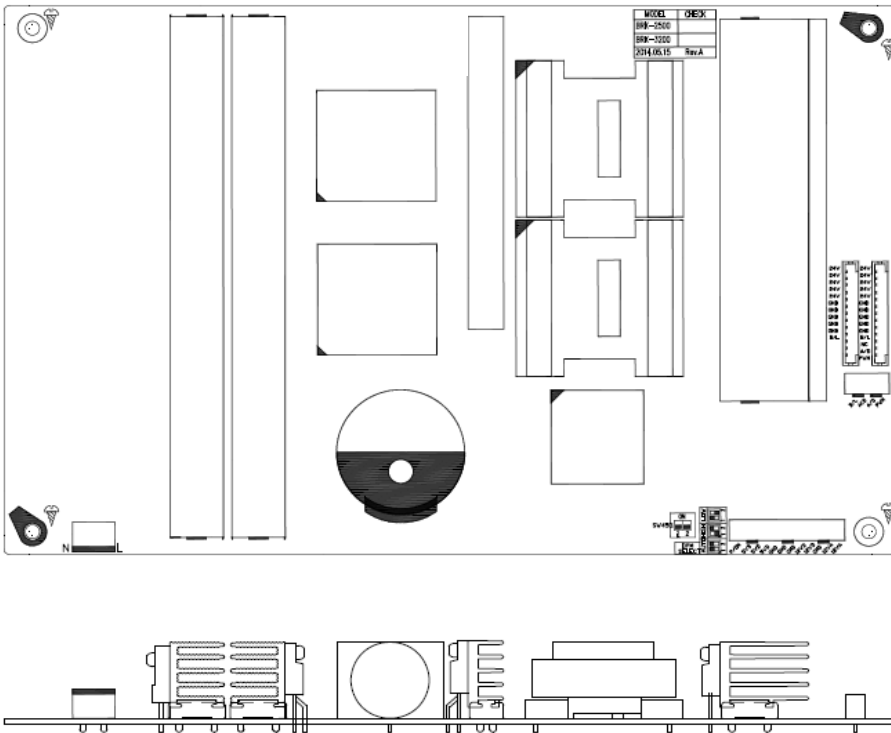

-[Not recommending] Not appropriate assembly position that disturbs SMPS heat dissipation and convection flow.

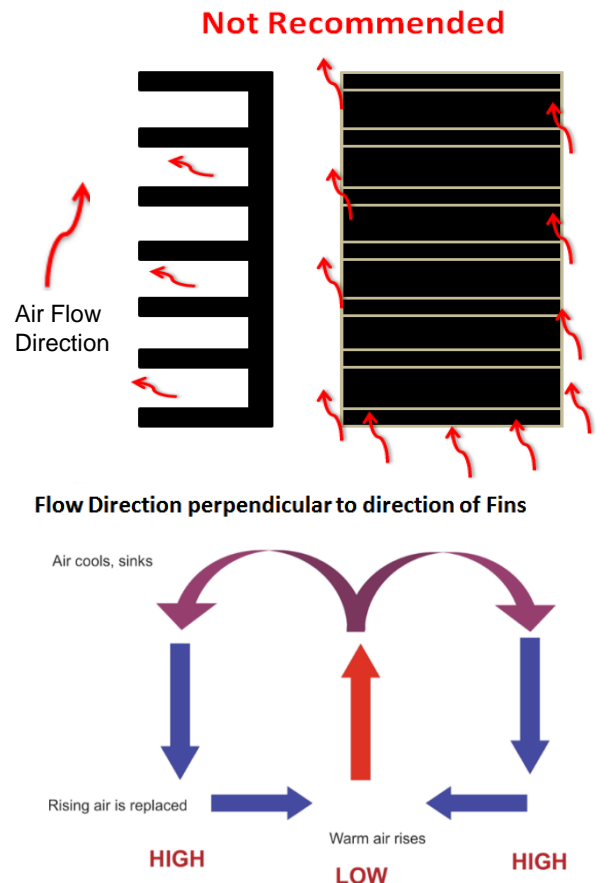
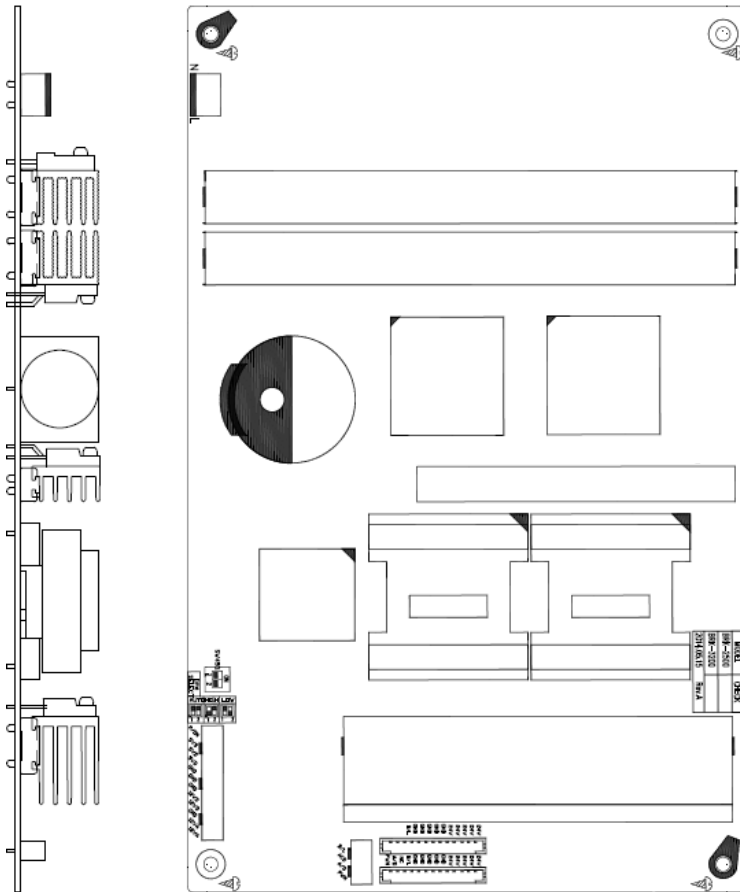

8. CONNECTOR PIN ASSIGNMENT & SPECIFICATION

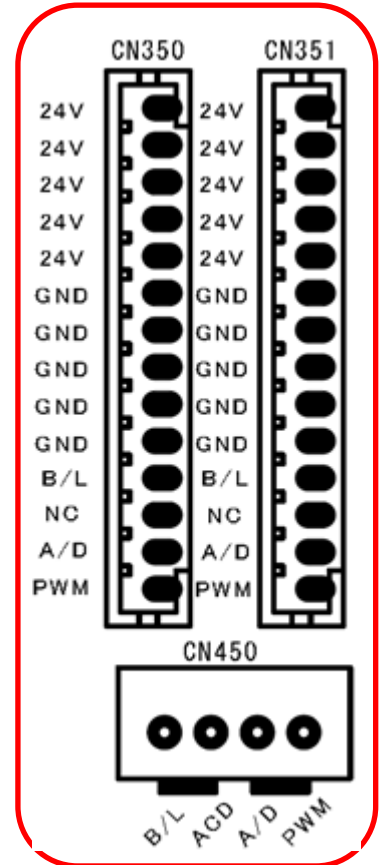
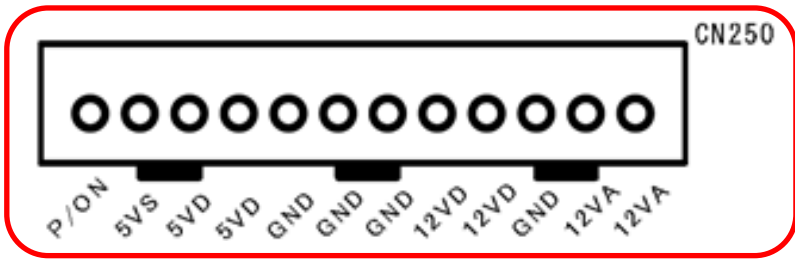
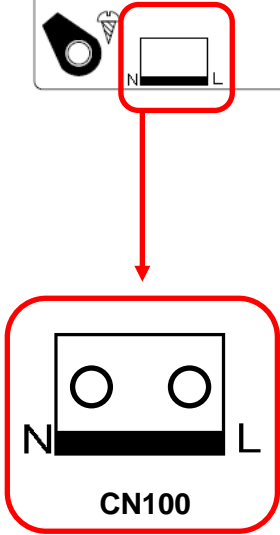
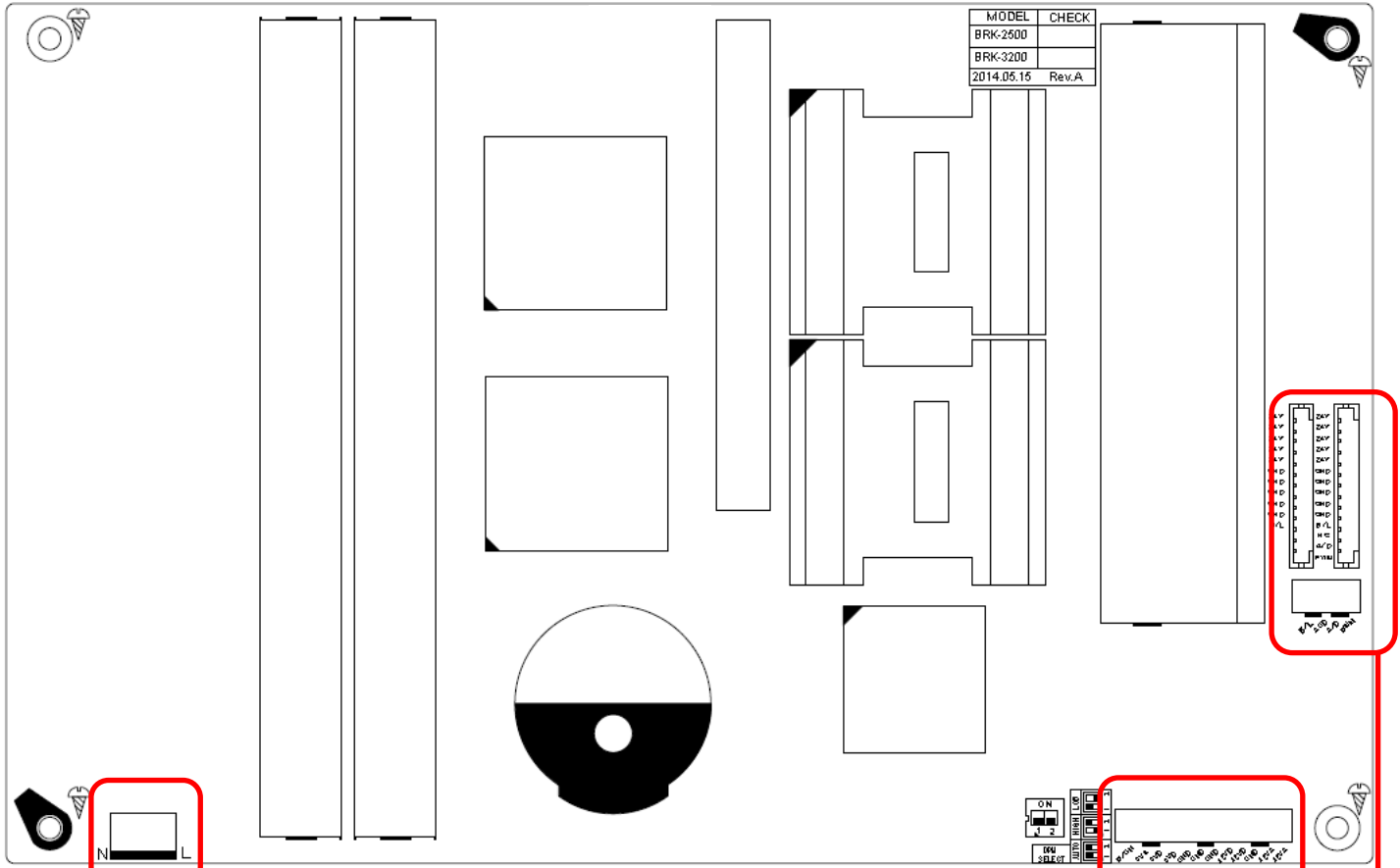

No.	Location No.	PART-NO.	VENDOR
1	CN100	YW396-03AV	YEONHO
2	CN250	SMW250-12	YEONHO
3	CN350	20010WS-14	YEONHO
4	CN351	20010WS-14	YEONHO
5	CN450	SMW250-04	YEONHO

8. P.C.B ASSEMBLY DIMENSION

- Size : 271(W) × 158(L) Height : MAX. 25mm(From the top of P.C.B)
- Weight : 920g max

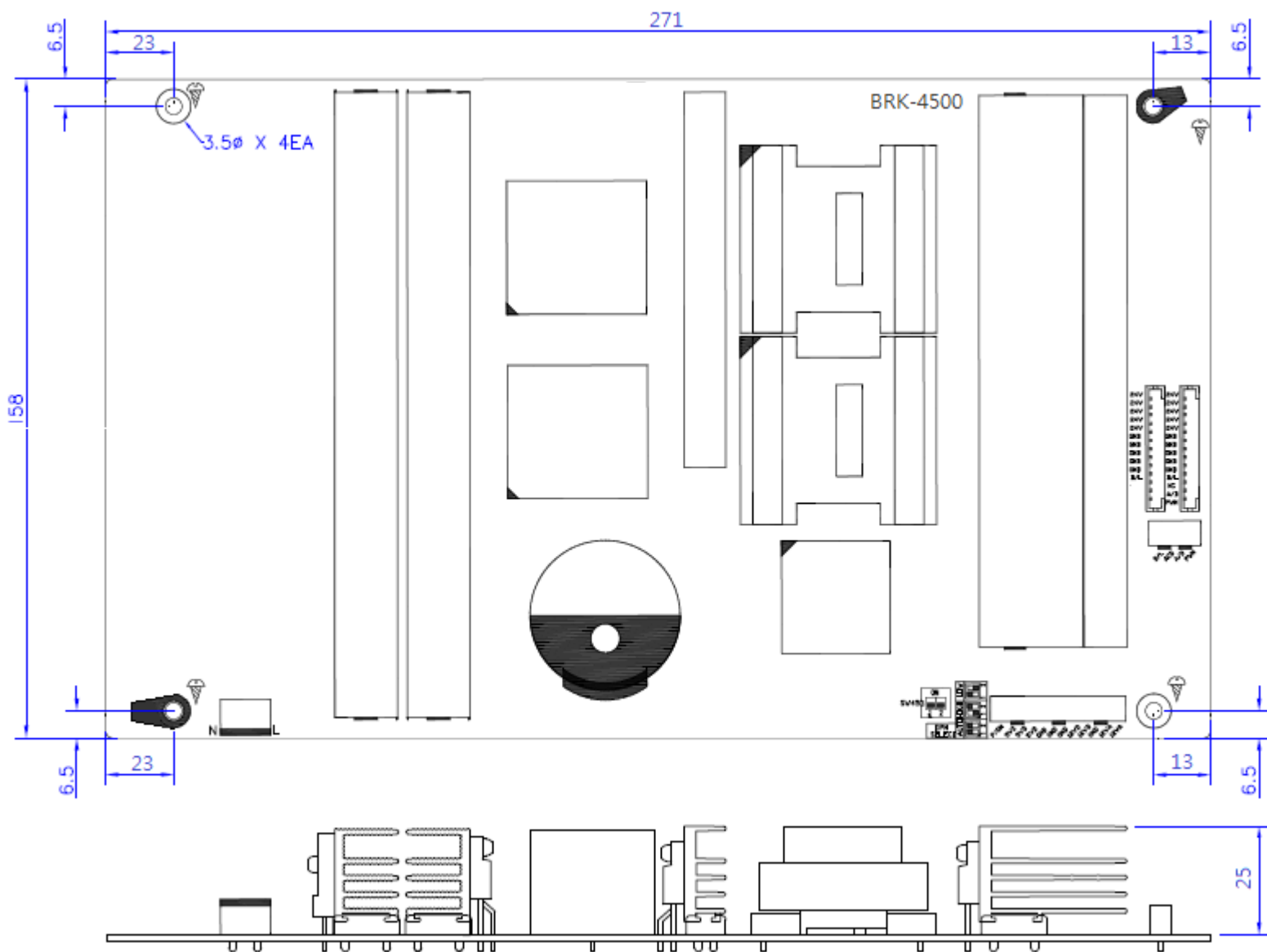

BLOCK DIAGRAM

BLOCK DIAGRAM

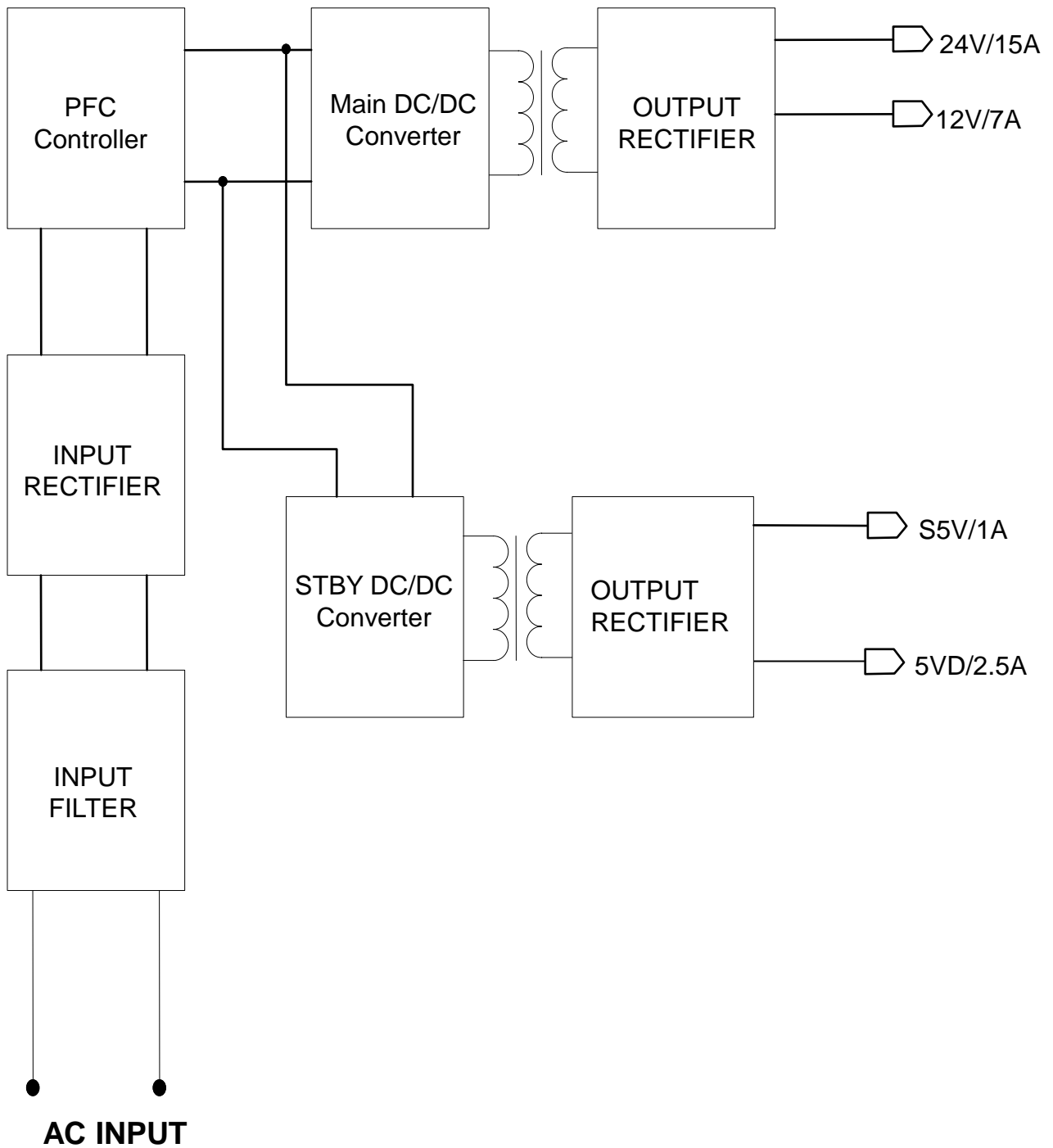

BAR-CODE LABEL DESCRIPTION



S/N : GP2201019AA00001

